

Upgrade your bottling line

With SKF and Lincoln automatic lubrication systems



Manual lubrication challenges you daily

Consider the risk of over- or under-lubrication and the cost of downtime with no production.

The machinery is characterised by very different design aspects and movements. The lubrication requirements for each machine must be analyzed individually. Manual lubrication can be performed only when production is stopped.

Consider the time needed to manually lubricate each lubrication point and the potential for accidents.

To lubricate one lubrication point manually takes an average of two minutes, including walking distances, checking maintenance plan and lubrication cycle, cartridge changes, etc. This takes place in demanding working conditions such as humidity, height and vibration.

Consider the cost of lubricants and their management.

Various machines demand different lubricants, dosages per lubrication point and frequencies. This makes lubrication management quite complex and involves considerations ranging from lubricant inventory to creation and maintenance of lubrication routes.

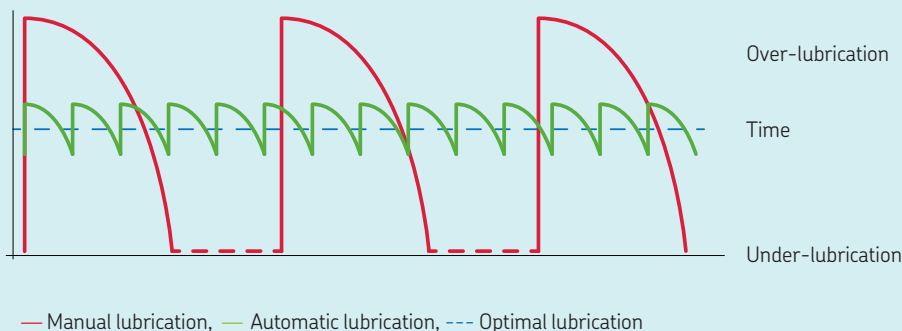

Realize the true potential of lubrication for your application



The beverage industry is becoming more competitive. Growing consumption demands 24-hour production that leaves little time for maintenance stops, so maintenance tasks must be done while equipment is operating. Targeted at more than 80 percent, Overall Equipment Effectiveness (OEE) often is around 60 percent, and machinery breakdowns dramatically affect availability. However, automating essential tasks like lubrication eliminates human mistakes, simplifies lubrication management, reduces lubricant consumption and enhances line efficiency.

Examples of how SKF lubrication solutions can help customers.

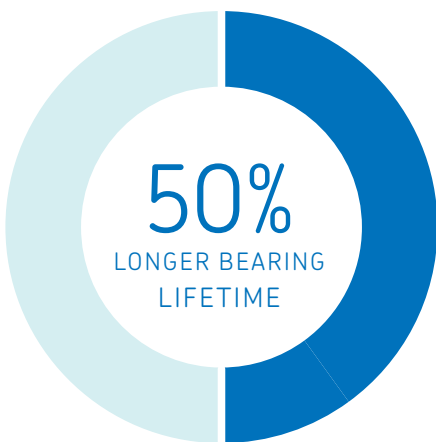

When changing from manual lubrication to SKF progressive automatic lubrication systems, a large brewery could increase the bearing life on conveyor belts by 50%. At the same time, the number of failures caused by improper manual lubrication could be reduced significantly.

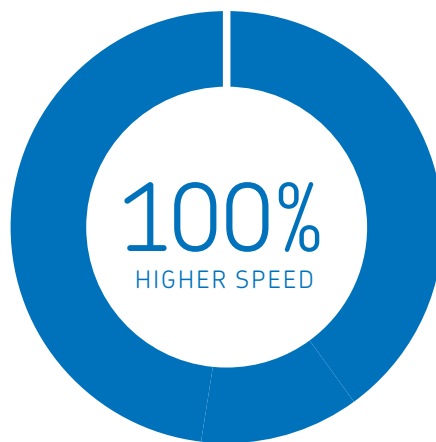

A bottling plant could increase the speed of a spiral conveyor / accumulator by nearly 100% after retrofitting an SKF automatic lubrication system. Utilizing a single-line spraying system, the transmission chains can run faster without damaging the bottles.



One of the world's largest soft drink producers could decrease downtime significantly by replacing an existing lubrication system that is prone to failures, which result in complete production shutdowns. An SKF or Lincoln sectional lubrication system with robust and reliable components could provide a solution.

The right lubrication solution for your plant

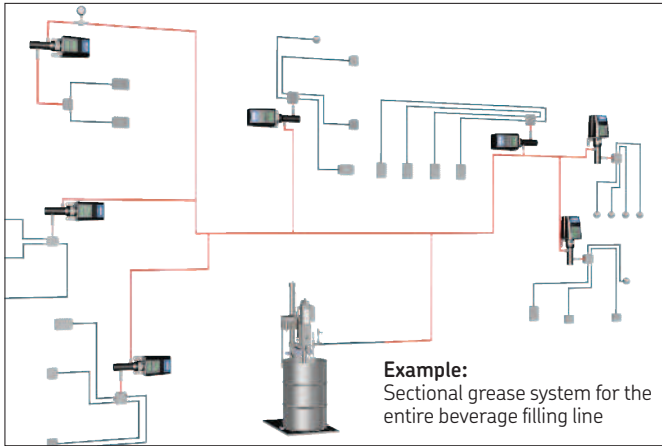

Regardless of retrofitting, expanding or reconfiguring, SKF offers a comprehensive range of lubrication systems for oil, fluid grease and grease, utilizing different working models for the entire beverage industry. Find the right solution for each application in wet or dry areas: single machines, conveyors, chains or the complete bottling plant.

The SKF portfolio includes a broad variety of solutions to lubricate chains and conveyors, as well as approved lubricants for use in manufacturing various food-type products.

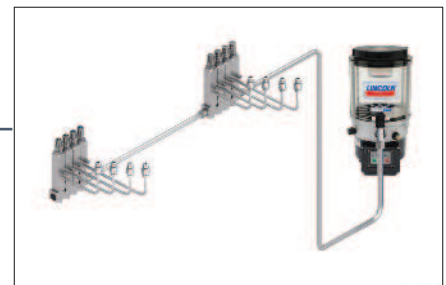
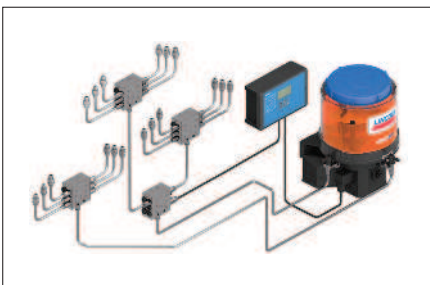
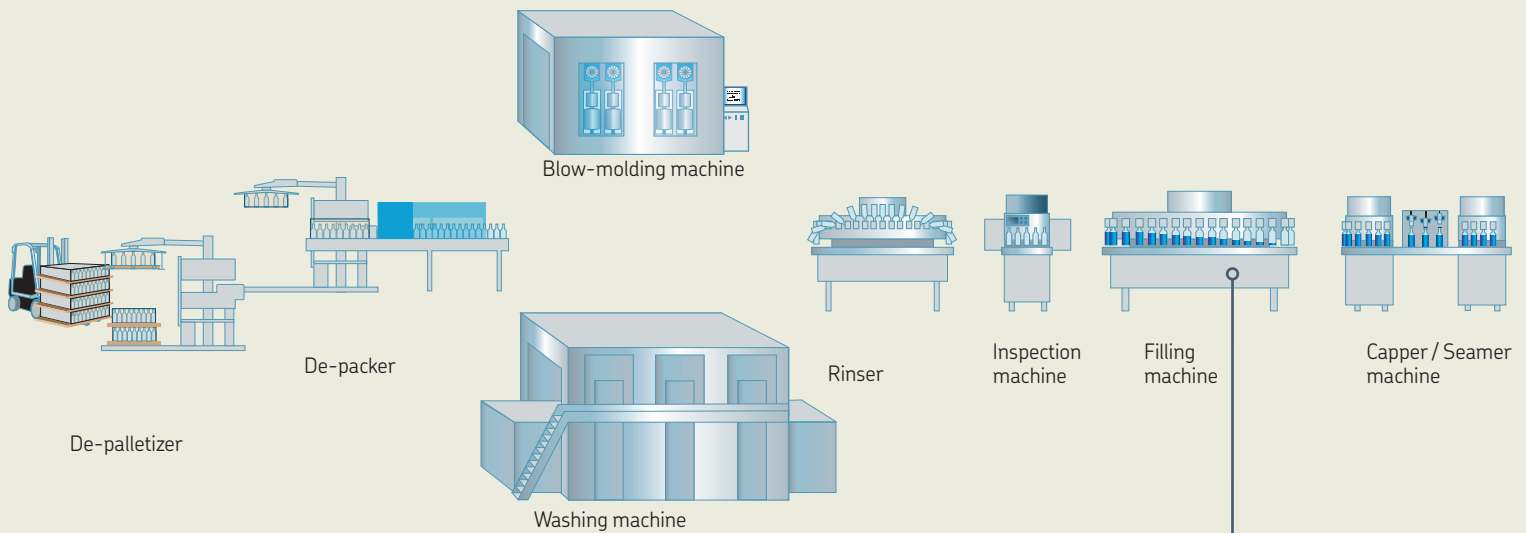

Example:
Dry lubrication for the top of the chain

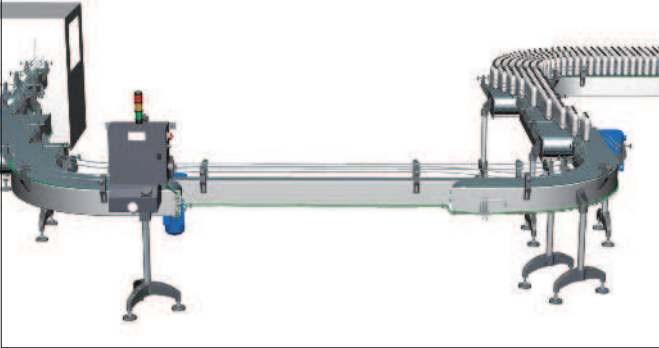

Example:
Food grade chain oil for transport chains in packaging machines

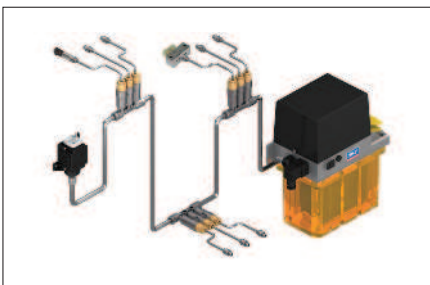
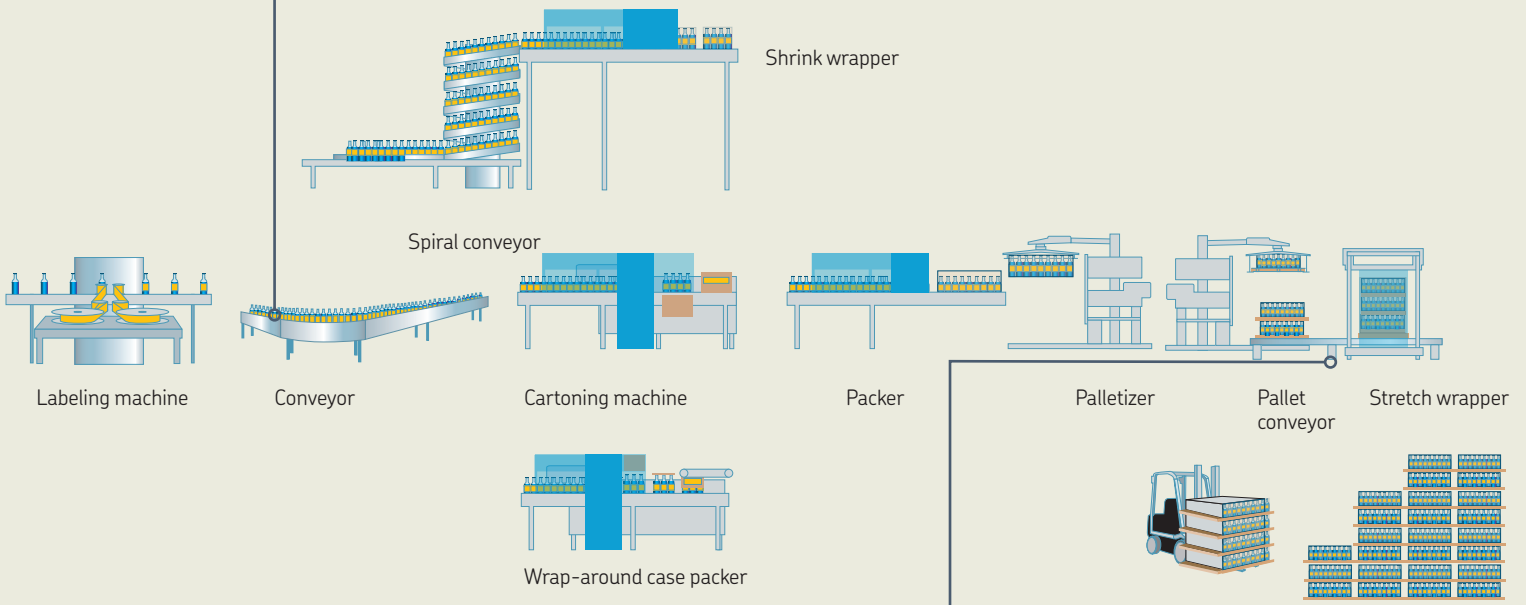

Example:
Single-line and progressive systems for pallet stretch wrappers
Special pallet conveyor chain lubrication solutions

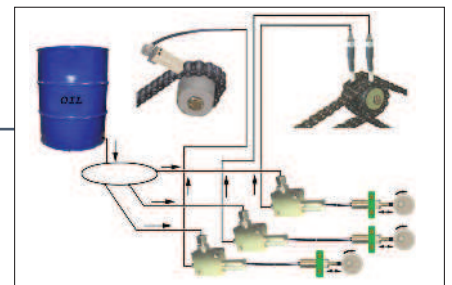

Optimize your lubrication

1 Manual single-point lubrication



2 Consolidate lubrication points

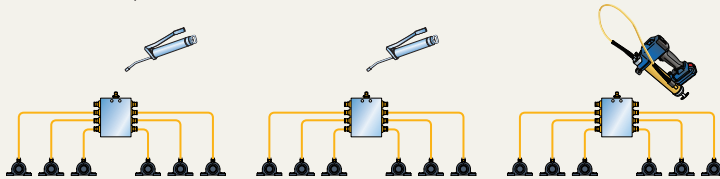

3 Centralized automatic lubrication system

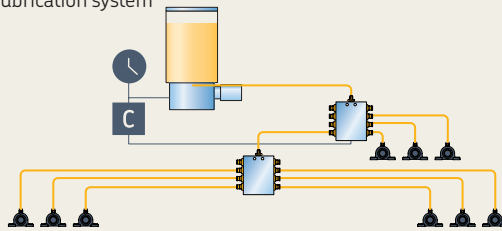

4 Enhanced sectional lubrication system with programmable control

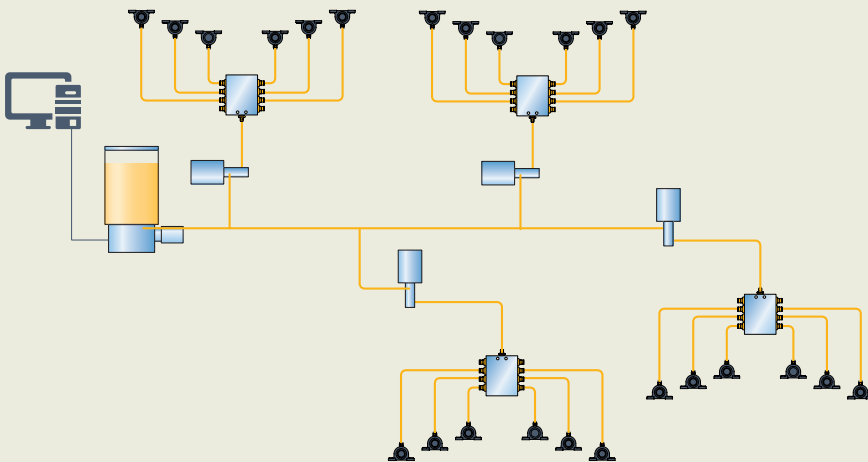

SKF offers a complete range of lubrication systems and equipment, whether you have just a few or a few thousand lubrication points.

- 1 Start with upgrading the lubrication tool in areas where you still want to lubricate manually. A battery-operated grease gun can help reduce maintenance time and effort. Also, you may want to consider single-point, automatic lubricators that can be mounted at the lubrication point. They support mid-term lubrication and basic lubrication cycles.
- 2 Consolidate multiple lubrication points into just one point to reduce time spent searching around the machine. Instead of several lubrication points, you serve just one.
- 3 Elevate the autonomy of lubrication by adding a pump, controlling and monitoring the entire system. This automatic lubrication system provides the appropriate lubricant at the right quantity at the correct intervals. These systems can be connected to machine controls as well.
- 4 In sectional lubrication systems, the lubricant is fed from a central lubricant reservoir and split into separate sections to serve machine parts with different lubrication requirements or located at varying distances. Step-by-step extension is possible. Our modules build upon each other, enabling the system to grow in accordance with customer requirements.

Choose the right lubricant



SKF Food Grade Lubricants are NSF H1 registered and Kosher and Halal certified. Additionally, they rely on the ISO 21469 standard, which helps ensure that they are produced and delivered according to the highest hygienic requirements.

For more information, see publication
→ **PUB MP/P1 03000 EN**

Upgrade the lubrication tool



Automatic lubricators deliver safety, reliability and efficiency and are suitable if you have only a few lubrication points to serve. SKF has developed around-the-clock solutions that provide precise amounts of contaminant-free grease with minimal risk of over- or under-lubrication.

For more information, see publication
→ **PUB MP/P8 17099 EN**



SKF offers a wide range of hand-held lubrication tools to help simplify your lubrication tasks. **Lincoln's PowerLuber** family provides the most extensive offering of battery-operated grease guns.

For more information, see publication
→ **PUB LS/P2 14470 EN**

Consolidate lubrication points

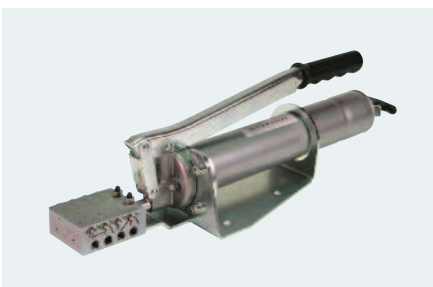

Connecting pumps directly to progressive metering devices helps to supply lubricant evenly to all associated lubrication points. For instance, consolidate the lubrication points of a de-packer and bring them outside of the cage. This reduces lubrication time and provides reliable dosage and easier access to lubrication points.

For more information, see publication
→ **PUB LS/P1 16964 EN**

Upgrade to a centralized automatic lubrication system

SKF offers a comprehensive range of both oil and grease lubrication systems utilizing different working models. In addition, our portfolio includes a broad variety of solutions to lubricate chains. Complete plant lubrication supply systems provide lubricant to an entire network of systems from a single source.

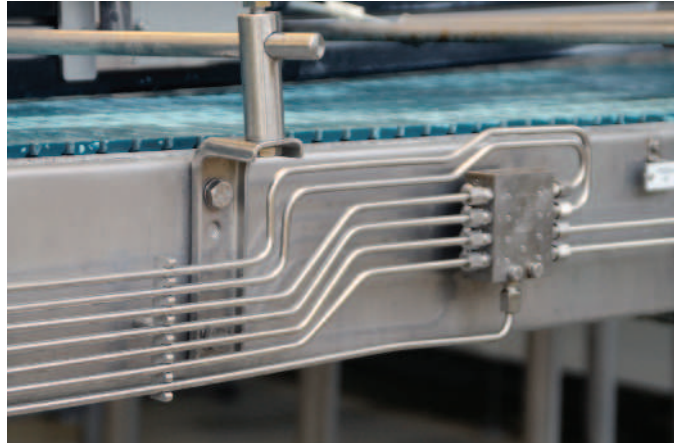

No matter which lubrication system best suits the application, SKF offers a comprehensive range of quality lubrication pumps, metering devices, control and monitoring units and all necessary accessories.

Materials

Materials used in wet areas must comply with specific regulations, enable easy cleaning and avoid corrosion. SKF components for these areas are coated for protection against corrosion and combined with stainless steel.

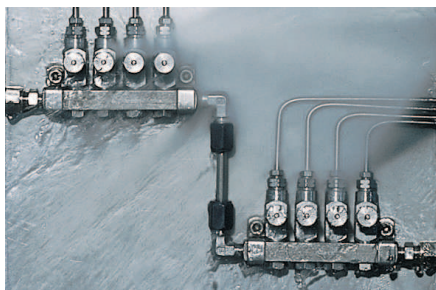

Lubrication pumps

Criteria, such as ambient conditions, required delivery rates, lubricants employed and service intervals, determine which lubrication pump should be selected. Pumps are available with various control and monitoring options.

SKF offers mechanically, electrically, hydraulically and pneumatically driven pumps. All pump housings are environment-resistant. In addition, the pumps are suitable for oil and standard greases up to and including NLGI Grade 2.

Lubricant metering devices

Different lubrication systems require different metering devices. All SKF and Lincoln lubricant metering devices are high-precision components. Several designs are suitable for high-pressure applications, and system operation can be verified easily through electronic or visual monitoring. SKF's offering is completed by additional system components such as spraying nozzles or brushes.

Monitoring

Monitoring and control are essential to the efficient operation of lubrication systems. Installed in conjunction with intelligent monitoring devices, automatic lubrication systems can facilitate economical and optimal lubrication.

With the instruments SKF provides, you have access to all values important for controlling your system – temperature, pressure, volumetric flow and fill level – whether visually or with digital or analog signal, time or load-dependent settings.

Progressive lubrication systems

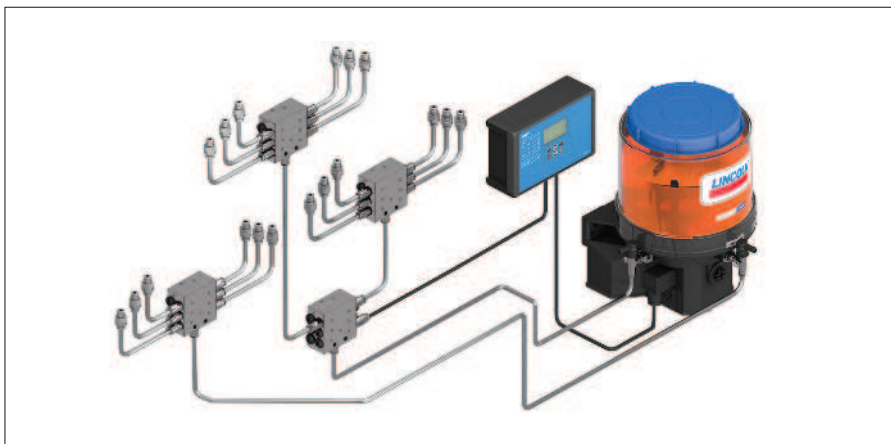

In SKF ProFlex and MultiFlex or Lincoln Quicklub progressive automatic lubrication systems, a piston pump supplies a defined amount of lubricant through the main line to the metering device that serves each outlet.

SKF's progressive systems can dispense a precise, metered amount of lubricant to up to 150 lubrication points over distances of approximately 15 m (16 yd). For oil applications, even in connection with flow limiters, these systems cover distances of more than 100 m (110 yd).

For more information, see
→ www.skf.com/progressive

Benefits:

- Continuous lubrication
- Delivers frequent and measured amounts of lubricant to each lubrication point
- Reliable monitoring and control
- Easy system monitoring and simple blockage control, integrated system control and monitoring
- Effective in harsh conditions: potentially high lubrication-point back pressure, dirty, wet or humid environments and low temperatures
- Stainless steel components available

Variety of applications:

- Grease lubrication systems for beverage machines such as:
 - bottle-washing machines
 - fillers
 - blow-molding machines
 - labelers, etc.
- Also the lubrication of bearings on conveyors is possible in small plants

Sectional lubrication systems

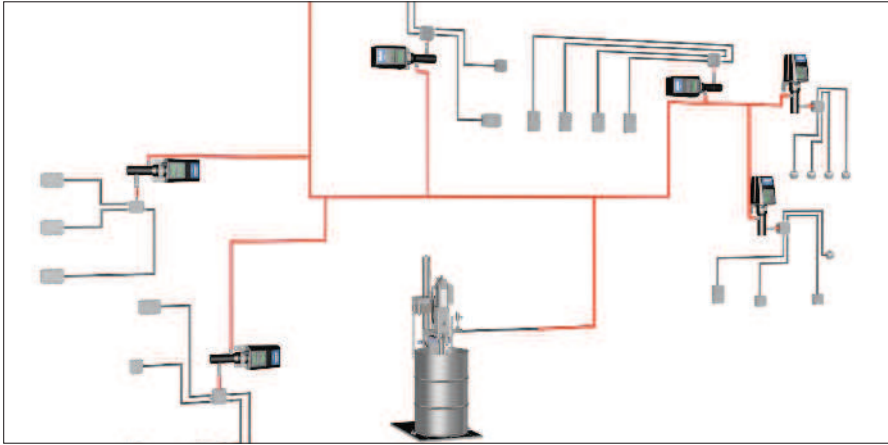

In sectional lubrication systems, the lubricant is fed from a central lubricant reservoir and split into separate sections to serve machine parts with different lubrication requirements or located at varying distances.

A combination of a single-line and progressive system concept, the sectional system is able to lubricate the entire filling or production line.

Since pressure loss is the toughest challenge through long-distance lubricant supply, special booster pumps (Electric Driven Lubricator EDL) provide enough power to bring the lubricant to each metering device inside the section and then to the lubrication point.

The system offers different lubrication options to support flexible system operation in each plant, regardless of whether the filling line requires independent lubrication or a machine-controlled or overall-plant-controlled operation. Each section works as a progressive system to lubricate, for example, the bearings of a conveyor's deviating shaft.

For more information, see

→ www.skf.com/edl1

Benefits:

- Cost-effective solution
Can be used with existing tubing, fitting material and barrel pumps
- Lower operational costs
No compressed air required; power consumption reduced
- Environmentally friendly
Electric power can be obtained using solar panels in outdoor applications
- Virtually maintenance free
No preventive maintenance necessary
- User-friendly design
Easy to setup and operate
- Remote monitoring
Fault or blockage signals are sent in case of lubrication failure
- Efficient
Low input pressure of 2 bar (29 psi) allows for retrofit installations in existing systems, enabling use of smaller, less-expensive main line

Variety of applications:

- Several complete sections
- Complete bottling line

Single-line lubrication systems

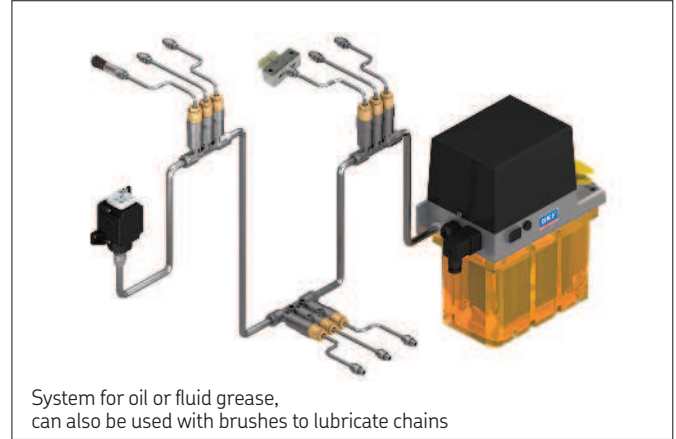
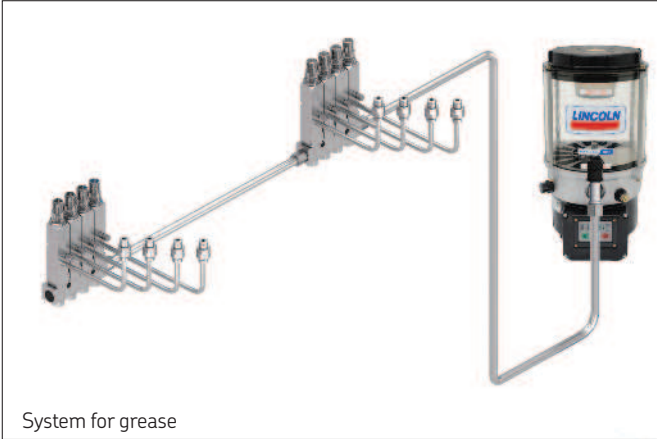

Regardless of the application, the principle of single-line lubrication remains the same: a central pump station automatically delivers lubricant through a single supply line to the lubricant metering device. Each metering device serves only one lubrication point and may be adjusted to deliver the precise amount of grease or oil required. Systems can service one machine, different zones on one machine or even several separate machines.

The SKF portfolio includes both SKF MonoFlex and Lincoln Centro-Matic system components such as pumps, metering units, control and monitoring devices and accessories.

For more information, see
→ www.skf.com/single-line

Benefits:

- Easy to understand, install and maintain
- Available in both preset and adjustable models
- Suitable for almost all lubricants
- Easy system expansion or modification
- System continues to operate if one point becomes blocked
- Integrated system control and monitoring
- Able to pump long distances and within a wide temperature range
- Stainless steel components available

Variety of applications:

- Grease lubrication for beverage machines such as:
 - fillers
 - cappers
 - labelers
 - seamers, etc.
- Fluid grease or oil systems for packaging machines such as:
 - pallet stretch wrappers
 - shrink wrappers
 - wrap-around case packers and many more

Chain lubrication systems

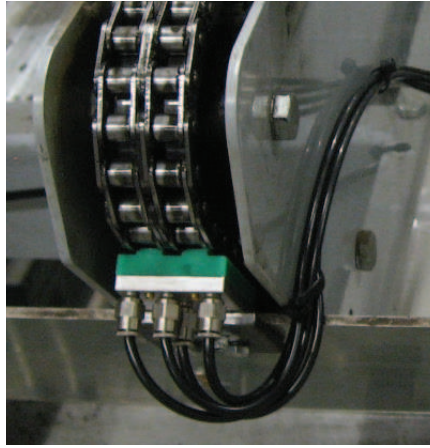

Transmission chains can be found throughout a bottling plant, activating internal parts of machines and driving conveying systems. These chains require continuous lubrication to reduce friction and wear, noise, higher energy consumption and, of course, unplanned production stops.

In most plants, lubrication is applied manually – a task that is often carried out while chains are running. This practice can result in accidents.

Inadequate lubrication and irregular lubrication cycles lead to breaks in the chain or links, resulting in a need for frequent chain replacement.

SKF offers a complete range of oil or grease lubrication systems for chains. These customized systems can be controlled and monitored by control units or special software.

For more information, see publication
→ **1-4106-EN**

Benefits:

- Higher productivity by eliminating unplanned production downtime for lubrication tasks
- Increased conveyor service life through reduction of chain wear
- Improved operator safety due to automation of the lubrication process
- Energy savings through decreased friction
- Benefits the environment via controlled and reduced lubricant consumption
- Corrosion-free components

Variety of applications:

- Chains on:
 - pallet conveyors
 - spiral conveyors
 - shrink wrappers
 - pallet stretch wrappers and more
- Intra-logistic conveying systems (pallets)

SKF Dry Lubrication Systems

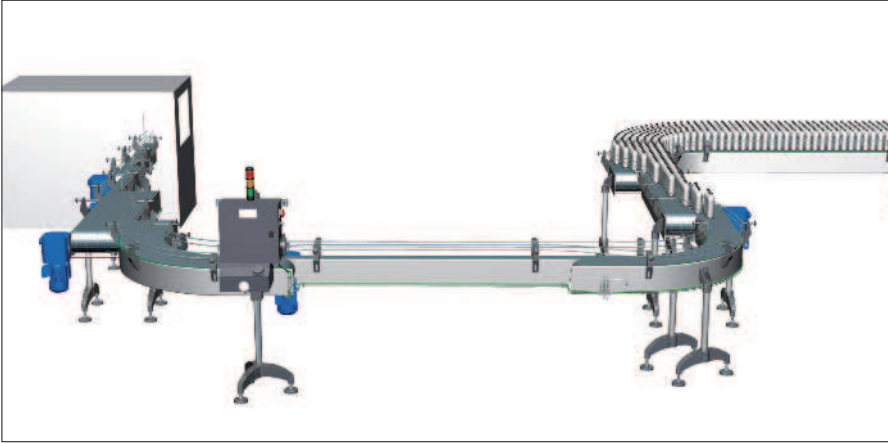

Flat-top conveyor chains require constant lubrication to prevent high friction between packages and chains in accumulation areas. The typical solution is to apply high volumes of a water and soluble lubricant mixture, which can cause operator accidents due to slippery floors or package quality issues resulting from organic development and moisture formation. The humid atmosphere can cause corrosion, which leads to replacement costs and reduced line efficiency.

The SKF Dry Lubrication System eliminates the need to spray thousands of litres of water and soluble lubricant. Instead, this flexible and completely automatic system applies a small amount of SKF Dry Film Lubricant (NSF H1 certified) on the conveyor chains and guides. As a result, floors are dry and lubricant consumption is minimal. Also, there is no more waste water, moisture on packages or corrosion.

The central unit can feed up to 200 lubrication points in accordance with the production process.

For more information, see publication
→ **PUB LS/S7 14617 EN**

Benefits:

- Cost savings by eliminating high volume of water and soluble lubricant
- Improved operator safety by reducing slip hazards
- Reduced risk of product contamination by avoiding microbiological growth
- Enhanced line efficiency

Application:

- Conveying systems for bottles with flat-top chains

Expertise and consultation



Follow the path toward a world-class lubrication programme

A lubrication management programme can be defined as the sum of all the activities performed in a given facility to help ensure the right lubricant is provided in the right quantity to the right point at the right time with the right method.

The SKF Lubrication Management programme defines a structured process to help you develop an effective lubrication programme throughout your facility.

Benefits of a world-class lubrication programme include cost savings related to:

- Downtime
- Spares
- Labour
- Overtime labour
- Energy consumption

Lubrication issues often are caused by:

- Lubricant contamination
- Lubricant chemical degradation
- Incorrect lubricant selection
- Insufficient or misleading knowledge

An efficient lubrication management programme should implement:

- Logistics and supply chain
- Lubricant selection
- Lubricant storage and handling
- Lubrication task planning and scheduling
- Lubricant application procedures
- Lubricant waste, handling and EHS compliance
- Training
- Automatic lubrication systems

The process consists of five major steps:

1 SKF Client Needs Analysis

SKF consultants will run a first assessment in your facility to sense the level of maturity of your lubrication programme and define a path to follow. This is normally a one-day activity.

2 SKF Lubrication Audit

When the level of complexity of the facility is high, or when the customer already has implemented basic improvements toward world-class lubrication, a thorough assessment is advised. This is normally a one-week activity.

3 Improvement proposal

After the required information is gathered, SKF will formulate proposals of specific activities that will help to improve the lubrication programme in place, in accordance with specific customer goals.

4 Design and implementation

After discussion and agreement, SKF can support the implementation of the improvement proposals. That support can be by means of equipment, training, consulting services, or even execution of specific tasks.

5 Optimisation

In order to measure the effectiveness of the programme, a reassessment is advised. That usually will open the door for new improvement opportunities that will lead you closer to your goals.

Global experience, global support, local installation



Here for you, wherever you are

SKF- and Lincoln-branded products, systems and services are available through a global network of distributor partners, supported by one unified sales organization committed to your success. System house distributors around the world offer turnkey solutions and extensive aftermarket support.

With lubrication application centres located on every continent and a worldwide distributor network, SKF has the people, products and support you need to optimize your lubrication management programme.

Partnering with SKF offers you access to the industry's most complete range of lubrication management solutions across the globe. Whatever the size or design of your machines, SKF has the products and resources to help you increase bearing life, machine uptime and safety, while minimizing manpower hours, maintenance costs and environmental impact.

Retrofitting lubrication systems

Maintenance and repair costs during system downtime quickly can become unwieldy. That is why we offer on-site professional retrofitting of centralized lubrication systems at your location. We also can assume responsibility for maintenance and repair during ongoing operations.

In addition, our portfolio includes other solutions that can simplify maintenance for you, from electric refilling pumps to appropriate fittings and accessories.





skf.com | skf.com/lubrication | lincolnindustrial.com

© SKF and Lincoln are registered trademarks of the SKF Group.

© SKF Group 2017

The contents of this publication are the copyright of the publisher and may not be reproduced (even extracts) unless prior written permission is granted. Every care has been taken to ensure the accuracy of the information contained in this publication but no liability can be accepted for any loss or damage whether direct, indirect or consequential arising out of the use of the information contained herein.

PUB LS/S2 17535 EN · September 2017

Certain image(s) used under license from Shutterstock.com.